

NJSR

SIZE	P	L <sub>1</sub>	L <sub>2</sub>	H	W	D	Q, TY
13 Su	10	78	70	50	100	33	
20 Su	15	90	80	54	100	38	
25 Su	20	97	85	64	130	47	

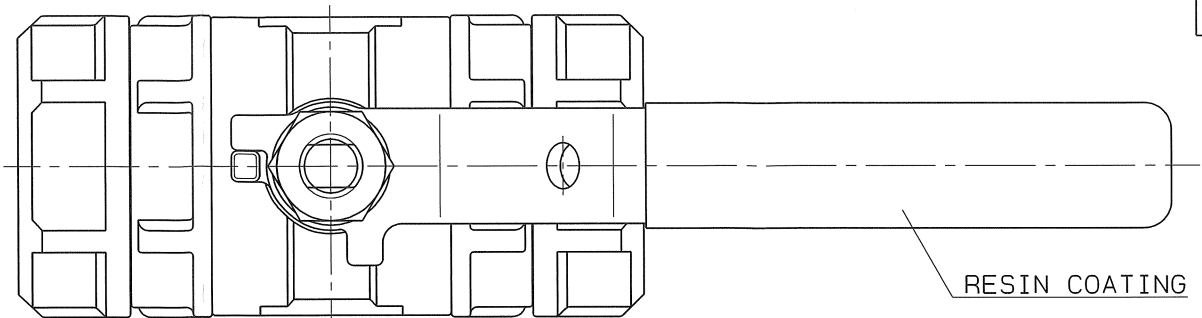

SPEC.			TEST PRESS.		
FLUID			SHELL	HYDRO 3.5	MPa
PRESS.	MAX	MPa	SEAT	AIR 0.6	MPa
TEMP.	MAX	℃	AIR		MPa

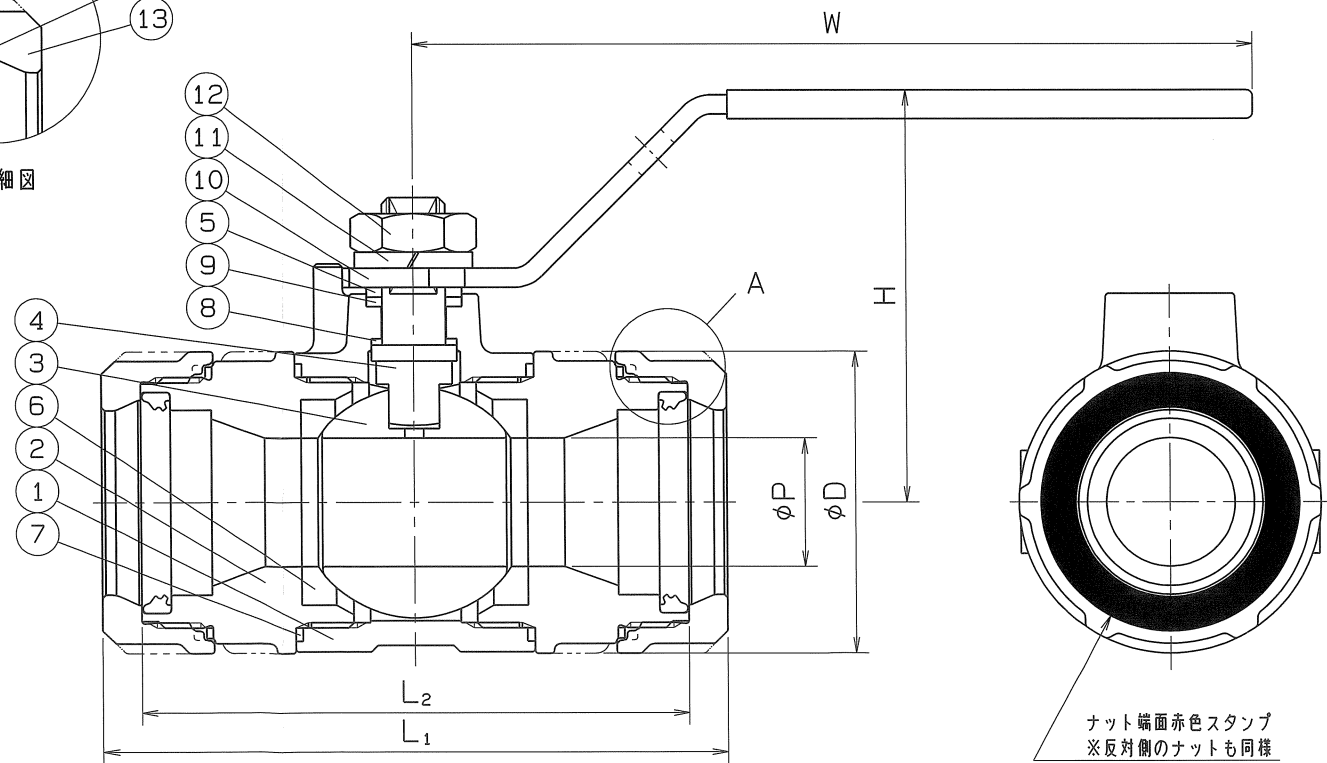
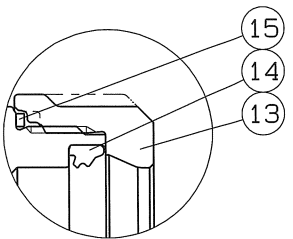
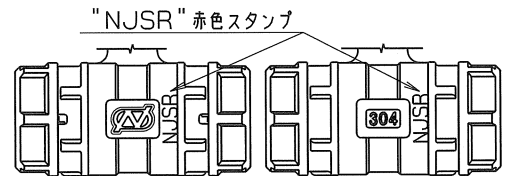

\*MODIFIED P.T.F.E.

15	LOOSE STOPPER	2	SUS 304CSP	
14	RUBBER PACKING	2	SYNTHETIC RUBBER (NJSR)	
13	RATCHET NUT	2	SCS 13	
12	HEXAGON NUT	1	SUS 304	
11	SPRING WASHER	1	SUS 304	
10	HANDLE	1	SUS 304	
9	THRUST BEARING	1	P.T.F.E.	CARBON FILLED
8	THRUST PACKING	1	P.T.F.E.	CARBON FILLED
7	GASKET PACKING	2	P.T.F.E.	
6	BALL SEAT	2	P.T.F.E.	*
5	GLAND	1	SUS 316	
4	STEM	1	SUS 316	
3	BALL DISC	1	SCS 13A	13su-SUS 304
2	BODY CAP	2	SCS 13	
1	BODY	1	SCS 13	
No.	NAME OF PARTS	Q.TY	MATERIALS	REMARKS

NAME	NICE JOINT ENDS REDUCED BORE MINI BALL VALVES		
TYPE	NJX-310	SIZE	13~25Su
DNQ.No.	XBAMS-0035◇	DATE	NOV. 6.2023.
THIRD ANGLE PROJECTION METHOD	SCALE :		

APPROVED	CHECKED	DESIGNED	DRAWN

O. N. INDUSTRIES LTD.
