

NJSR

SPEC.			TEST PRESS.	
FLUID			SHELL	HYDRO 3.5 MPa
PRESS.	MAX	MPa	SEAT	AIR 0.6 MPa
TEMP.	MAX	℃	AIR	MPa

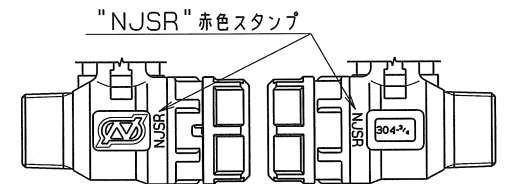
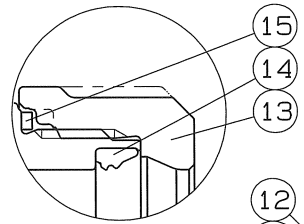
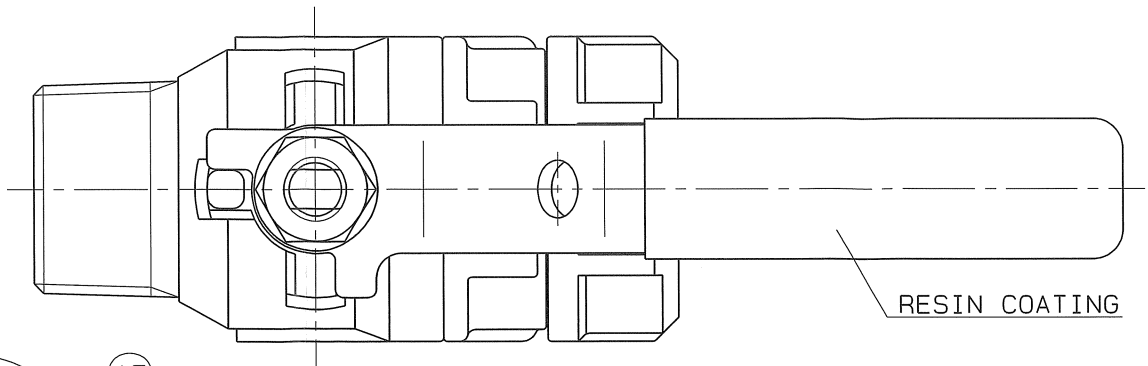

外觀図

PIPE THREADS CONFORM WITH "JIS B 0203"
*MODIFIED P.T.F.E.

No.	NAME OF PARTS	Q. TY	MATERIALS	REMARKS
15	LOOSE STOPPER	1	SUS 304CSP	
14	RUBBER PACKING	1	SYNTHETIC RUBBER (NJSR)	
13	RATCHET NUT	1	SCS 13	
12	HEXAGON NUT	1	SUS 304	
11	SPRING WASHER	1	SUS 304	
10	HANDLE	1	SUS 304	
9	THRUST BEARING	1	P.T.F.E.	CARBON FILLED
8	THRUST PACKING	1	P.T.F.E.	CARBON FILLED
7	GASKET PACKING	1	P.T.F.E.	
6	BALL SEAT	2	P.T.F.E.	*
5	GLAND	1	SUS 316	
4	STEM	1	SUS 316	
3	BALL DISC	1	SCS 13A	
2	BODY CAP	1	SCS 13	
1	BODY	1	SCS 13	

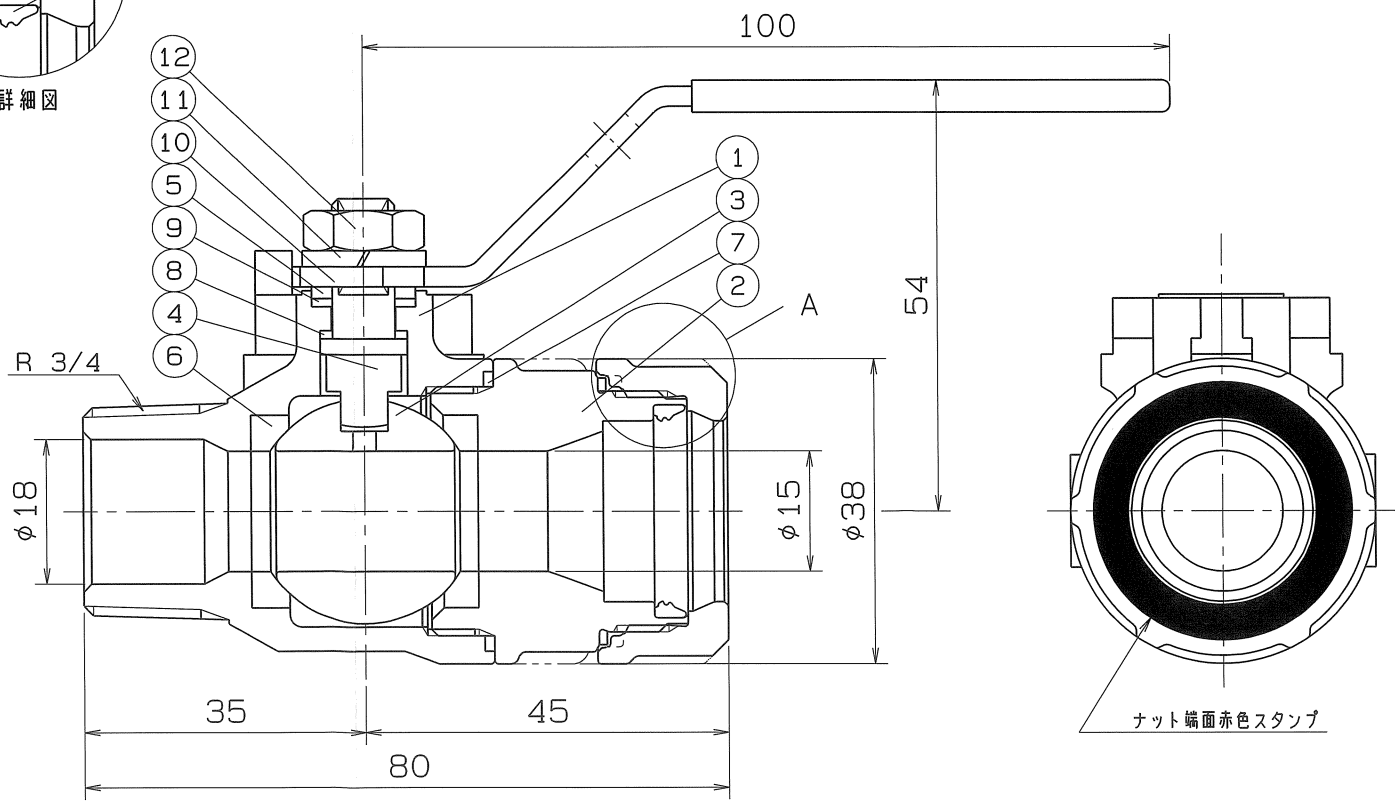

NAME	NICE JOINT AND SCREWED ENDS MINI BALL VALVES		
TYPE	NJX-611	SIZE	20Su x 3/4B
Dwg. No.	XBAMS-0034◇	DATE	NOV. 6. 2023.
THIRD ANGLE PROJECTION METHOD	SCALE		

APPROVED	CHECKED	DESIGNED	DRAWN

O. N. INDUSTRIES LTD.

△		
△		
△		