

◇ 6000-SWVBX '09.09.02

SIZE	P	L ₁	L ₂	H	W	D	Q, TY
13 Su	15	83	75	87	60	38	
20 Su	20	95	85	94	80	46.5	

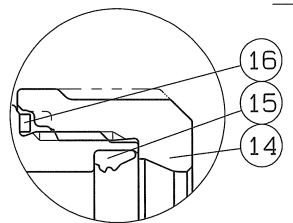

A部詳細図

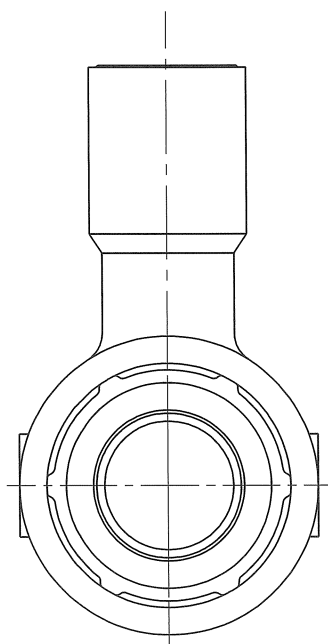
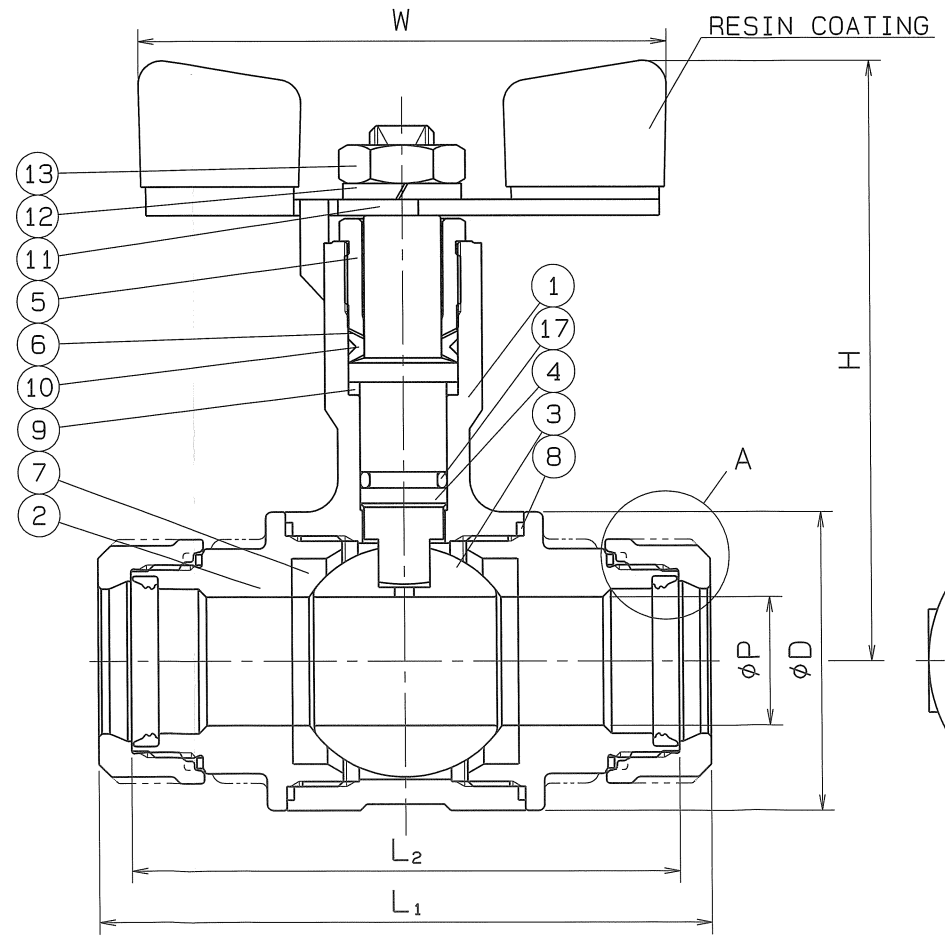
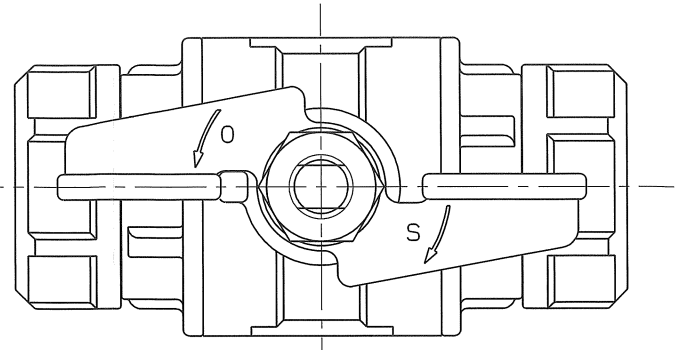

SPEC.		TEST PRESS.	
FLUID		SHELL	HYDRO 3.5 MPa
PRESS.	MAX MPa	SEAT	AIR 0.6 MPa
TEMP.	MAX ℃	AIR	MPa

*MODIFIED P.T.F.E.

No.	NAME OF PARTS	Q.TY	MATERIALS	REMARKS
17	O RING	1	FKM	
16	LOOSE STOPPER	2	SUS 304CSP	
15	RUBBER PACKING	2	SYNTHETIC RUBBER (HNBR)	
14	RATCHET NUT	2	SCS 13	
13	HEXAGON NUT	1	SUS 304	
12	SPRING WASHER	1	SUS 304	
11	HANDLE	1	SUS 304	
10	GLAND PACKING	1	P.T.F.E.	
9	BEARING	1	P.T.F.E.	CARBON FILLED
8	GASKET PACKING	2	P.T.F.E.	
7	BALL SEAT	2	P.T.F.E.	*
6	WASHER	1	SUS 304CSP	
5	GLAND BUSHING	1	SCS 13	
4	STEM	1	SUS 304	
3	BALL DISC	1	SCS 13A	
2	BODY CAP	2	SCS 13	
1	BODY	1	SCS 13	

NAME	NICE JOINT ENDS FULL BORE LONG NECK TYPE MINI BALL VALVES		
TYPE	NJX-220	SIZE	13, 20Su
DWG No.	XBAMS-0009◇	DATE	MAR. 14. 2023.
THIRD ANGLE PROJECTION METHOD	SCALE		

APPROVED	CHECKED	DESIGNED	DRAWN

O. N. INDUSTRIES LTD.