

SIZE	P	L ₁	L ₂	H	W	D	Q, TY
13 Su	10	78	70	46	60	33	
20 Su	15	90	80	50	60	38	
25 Su	20	97	85	58	80	47	

A
B
C
D
E
F

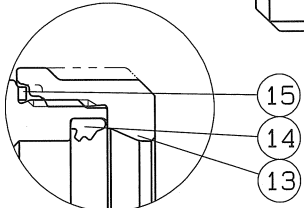

A部詳細図

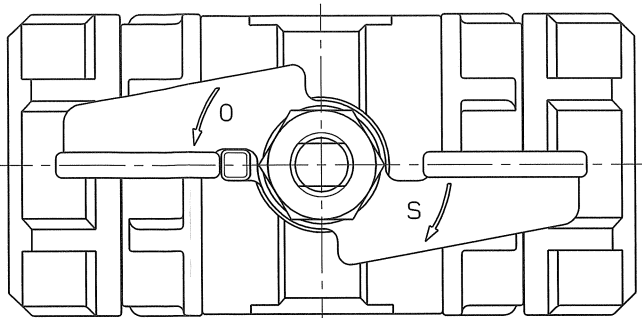
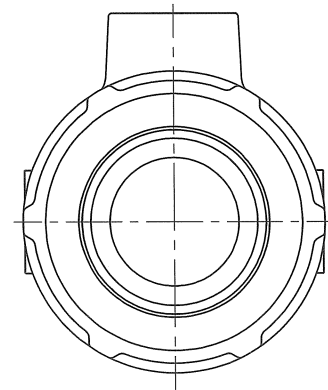
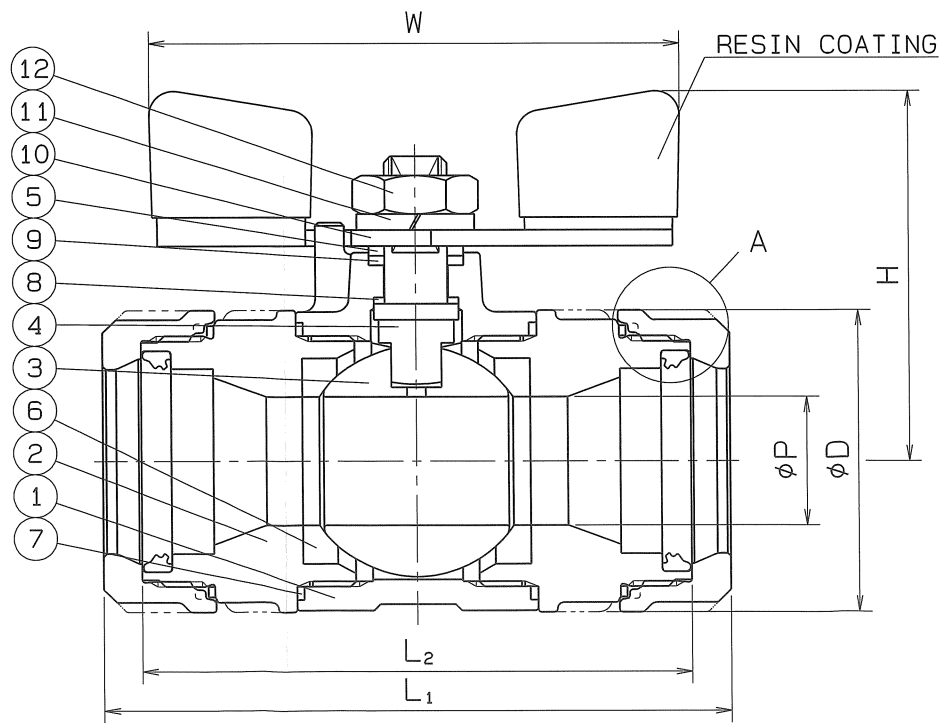

SPEC.			TEST PRESS.	
FLUID			SHELL	HYDRO 3.5 MPa
PRESS.	MAX	MPa	SEAT	AIR 0.6 MPa
TEMP.	MAX	℃	AIR	MPa

*MODIFIED P.T.F.E.

No.	NAME OF PARTS	Q.TY	MATERIALS	REMARKS
15	LOOSE STOPPER	2	SUS 304CSP	
14	RUBBER PACKING	2	SYNTHETIC RUBBER (HNBR)	
13	RATCHET NUT	2	SCS 13	
12	HEXAGON NUT	1	SUS 304	
11	SPRING WASHER	1	SUS 304	
10	HANDLE	1	SUS 304	
9	THRUST BEARING	1	P.T.F.E.	CARBON FILLED
8	THRUST PACKING	1	P.T.F.E.	CARBON FILLED
7	GASKET PACKING	2	P.T.F.E.	
6	BALL SEAT	2	P.T.F.E.	*
5	GLAND	1	SUS 316	
4	STEM	1	SUS 316	
3	BALL DISC	1	SCS 13A	13Su-SUS 304
2	BODY CAP	2	SCS 13	
1	BODY	1	SCS 13	

NAME	NICE JOINT ENDS REDUCED BORE MINI BALL VALVES		
TYPE	NJX-310	SIZE	13~25Su
Dwg. No.	XBAMS-0018◇	DATE	MAR. 14. 2023.
THIRD ANGLE PROJECTION METHOD	SCALE :		

APPROVED	CHECKED	DESIGNED	DRAWN
