

A部詳細図

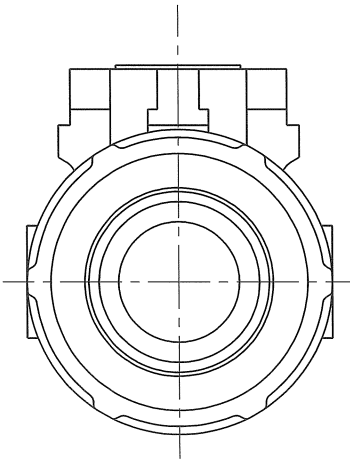
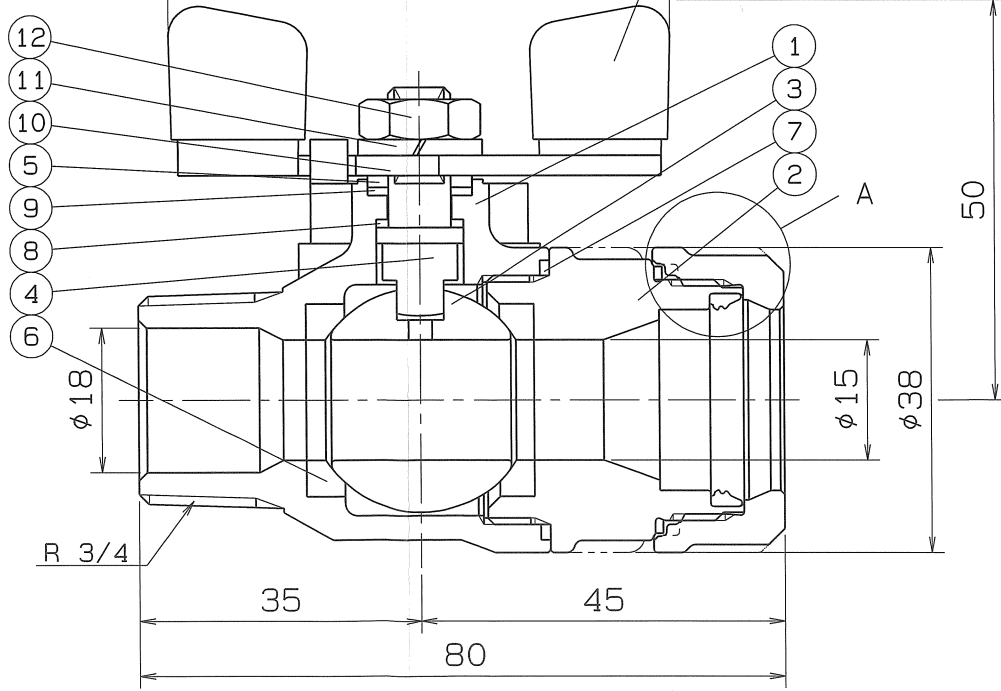

SPEC.		TEST PRESS.	
FLUID		SHELL	HYDRO 3.5 MPa
PRESS.	MAX MPa	SEAT	AIR 0.6 MPa
TEMP.	MAX ℃	AIR	MPa

PIPE THREADS CONFORM WITH "JIS B 0203"  
\*MODIFIED P.T.F.E.

No.	NAME OF PARTS	Q.TY	MATERIALS	REMARKS
15	LOOSE STOPPER	1	SUS 304CSP	
14	RUBBER PACKING	1	SYNTHETIC RUBBER (HNBR)	
13	RATCHET NUT	1	SCS 13	
12	HEXAGON NUT	1	SUS 304	
11	SPRING WASHER	1	SUS 304	
10	HANDLE	1	SUS 304	
9	THRUST BEARING	1	P.T.F.E.	CARBON FILLED
8	THRUST PACKING	1	P.T.F.E.	CARBON FILLED
7	GASKET PACKING	1	P.T.F.E.	
6	BALL SEAT	2	P.T.F.E.	*
5	GLAND	1	SUS 316	
4	STEM	1	SUS 316	
3	BALL DISC	1	SCS 13A	
2	BODY CAP	1	SCS 13	
1	BODY	1	SCS 13	

NAME NICE JOINT AND SCREWED ENDS  
MINI BALL VALVES

TYPE NJX-611 SIZE 20Sx3/4B

Dwg. No. XBAMS-0015 DATE MAR. 14. 2023.

THIRD ANGLE PROJECTION METHOD SCALE :

APPROVED	CHECKED	DESIGNED	DRAWN