

◇ 1000-SSV9X 'ON' 9MO

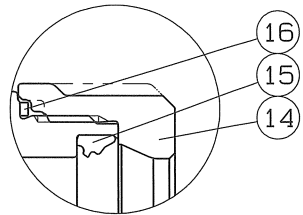

A部詳細図

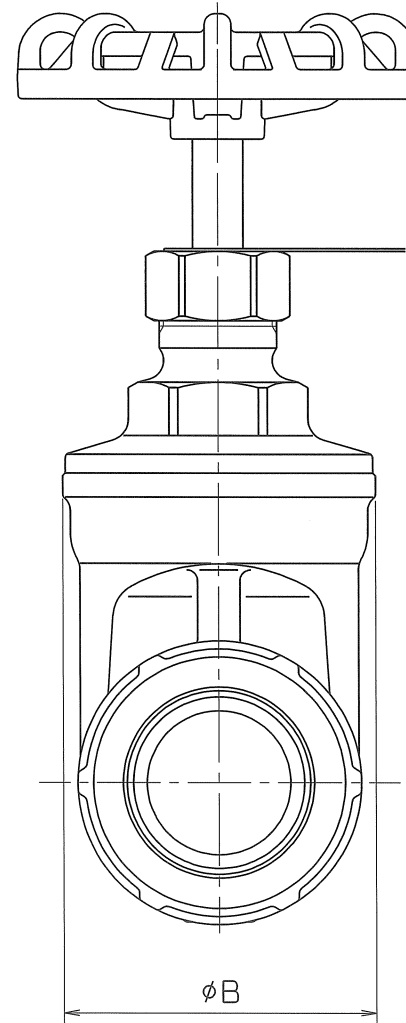
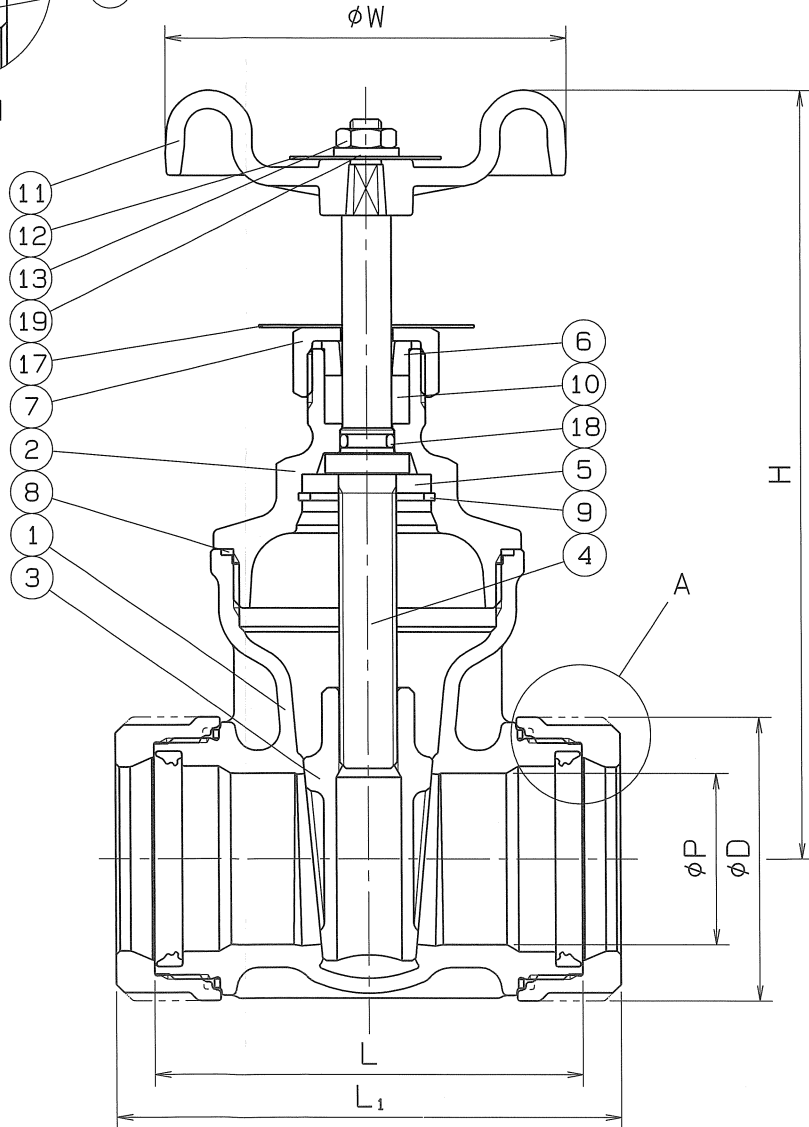

SIZE	L ₁	L	P	D	H	W	B	Q.TY
13Su	68	60	15	33	112	60	41.5	
20Su	76	66	20	38	115	60	45.5	
25Su	82	70	25	47	122	60	50	
30Su	94	80	32	53	143	75	58.5	
40Su	108	90	40	63	155	75	67	
50Su	120	100	46	71	182	95	79.5	
60Su	134	110	57.5	86	195	95	88	

SPEC.			TEST PRESS.	
FLUID			SHELL	HYDRO 3.5 MPa
PRESS.	MAX	MPa	SEAT	AIR 0.6 MPa
TEMP.	MAX	℃		AIR MPa

19	PLAIN WASHER	1	SUS 304	
18	O RING	1	FKM	
17	WARNING LABEL	1	PAPER	
16	LOOSE STOPPER	2	SUS 304CSP	
15	RUBBER PACKING	2	SYNTHETIC RUBBER (HNBR)	
14	RATCHET NUT	2	SCS 13	
13	HEXAGON NUT	1	SUS 304	
12	NAME PLATE	1	A1050P	
11	HAND WHEEL	1	ADC-12	
10	GLAND PACKING	1	ALAMIDE FIBER	
9	STOP RING	1	SUS 304	
8	GASKET	1	P.T.F.E.	
7	GLAND NUT	1	SCS 13	
6	GLAND	1	SUS 304	
5	STEM HOLDER	1	SUS 304	
4	STEM	1	SUS 304	
3	DISC	1	SCS 13	
2	BONNET	1	SCS 13	
1	BODY	1	SCS 13	
No.	NAME OF PARTS	Q.TY	MATERIALS	REMARKS

NAME	NICE JOINT ENDS GATE VALVES		
TYPE	NJX-670	SIZE	13~60Su
DMG.No.	XGASS-0001◇	DATE	MAR. 14. 2023.
THIRD ANGLE PROJECTION METHOD	SCALE :		
APPROVED	CHECKED	DESIGNED	DRAWN

O. N. INDUSTRIES LTD.